

CAD FILE:

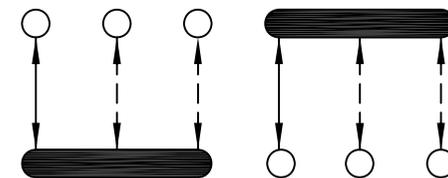

SCHEMATIC (SHORTING)

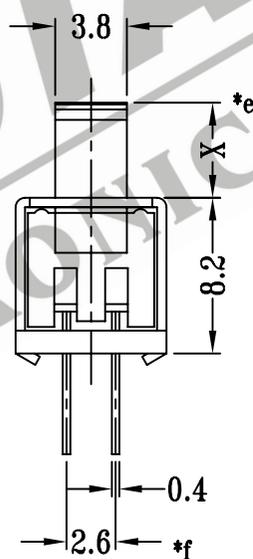
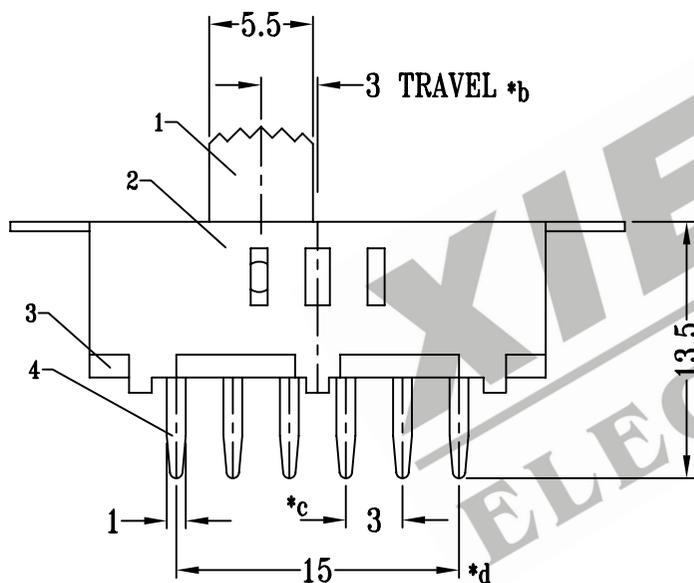
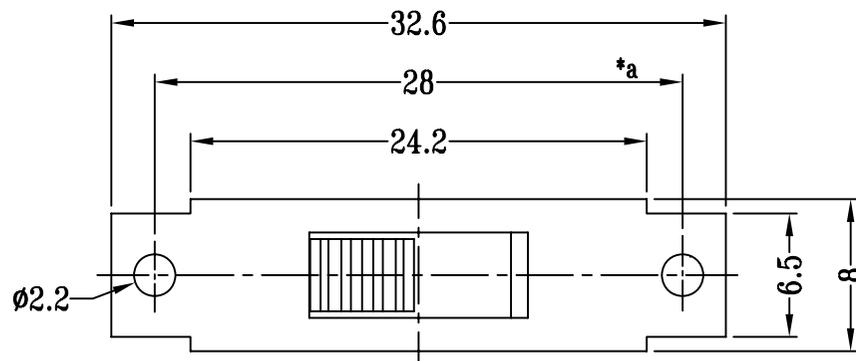
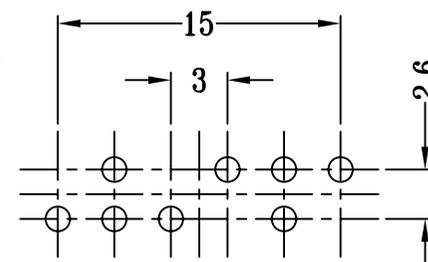

P.C.B LAYOUT

注：“*”表示关键尺寸(6个)

NO.	PARTS	MATERIALS	Q'TY	FINISH	TOLERANCE UNLESS SPECIFIED	SHENZHEN XIEJIA ELECTRONICS CO.,LTD.				
8						TITLE : VERTICAL SLIDE SWITCH	UNIT : mm	DRWG NO.: XJ-DR-SS23F14-00		
7	CONTACT CLIP	BRASS STRIP	2	Ag PLATED	WITHIN: 1.5±0.1mm OVER : 1.5±0.2mm			ISSUE	DATE	DESCRIPTIONS OF REVISION
6	SPRING	STEEL WIRE	3	TEMPER		MODEL: SS-23F14	SCALE: 5:2	DWN.	ZHOUYU	2004-3-12
5	STEEL BALL	STEEL	2	NATURAL				CHK'D	FANGYING	2004-3-12
4	TERMINAL	BRASS STRIP	8	Ag PLATED OVER Ni PLATED				APPD.	KANGXINAN	2004-3-12
3	BASE	PHENOLIC RESIN	1	BLACK				ALL MATERIALS MUST BE COMPLIANT TO ROHS		
2	FRAME	STEEL STRIP	1	BLACK						
1	KNOB	POM	1	BLACK						